

LTC SERIES

Mechanical Test Stand

The CHATILLON® LTC Series mechanical test stand features a manual handwheel that supplies rapid results for either tension or compression testing. The handwheel features self-locking screw. Stand travels 1-inch (25 mm) for every 10 turns. Durable and easy-to-use, this lightweight, single-column test stand is ideal for capacities up to 100 lbs (50 kg, 500 N). The maintenance-free design includes a hardened steel column, cast aluminum gauge clamp and cast iron base. The stand comes complete with lower plate for compression testing and a hook for tensile testing.

Extended height versions are available that expand the vertical clearance for large sample testing. Accessories include a dial indicator kit.

FEATURES

- Easy to Use, Rugged Construction
- Precision Manual Handwheel
- Capacities Up to 100 lbs (50 kg, 500 N)
- Maintenance-free Design
- Includes Compression Plate & Hook

SPECIFICATIONS

Capacity:	100 lbs (50 kg, 500N)
Stroke:::	3-3/8 inch (85.7 mm)
Vertical Clearance:	Up to 49-1/4 inches (1251 mm)
Weight:	11 lbs (5 kg)
Warranty:	2 Years



LTC shown with DFGS digital force gauge

SPECIFICATION
SS-FM-3121-1200
December 2000



Packaging



Electronics



Food & Beverage

INTERNET

www.ametek.com
www.chatillon.com
www.lloyd-instruments.co.uk

AMETEK and CHATILLON are registered trademarks of AMETEK, Inc.
LLOYD INSTRUMENTS is a trademark of AMETEK, Inc.

Copyright 2000, by AMETEK, Inc.
Printed in U.S.A

Chatillon®
A registered trademark of AMETEK, Inc.

ORDERING INFORMATION

(Order using Model Numbers at top of table)

Models	LTC	LTC-29	LTC-39	LTC-60
Capacity:	100 lbs (50 kg, 500 N)	100 lbs (50 kg, 500 N)	100 lbs (50 kg, 500 N)	100 lbs (50 kg, 500 N)
Stroke:	3-3/8 inch (85.7 mm)	3-3/8 inch (85.7 mm)	3-3/8 inch (85.7 mm)	3-3/8 inch (85.7 mm)
Vertical Clearance ¹ :	8-1/4 inch (209.5 mm)	18-1/4 inch (463.6 mm)	28-1/4 inch (717.6 mm)	49-1/4 inch (1251 mm)
Weight:	11 lbs (5 kg)	12 lbs (5.5 kg)	13 lbs (6 kg)	15 lbs (6.8 kg)
Warranty:	2 Years	2 Years	2 Years	2 Years

Note¹: Maximum clearance using remote load cell

DIMENSIONS

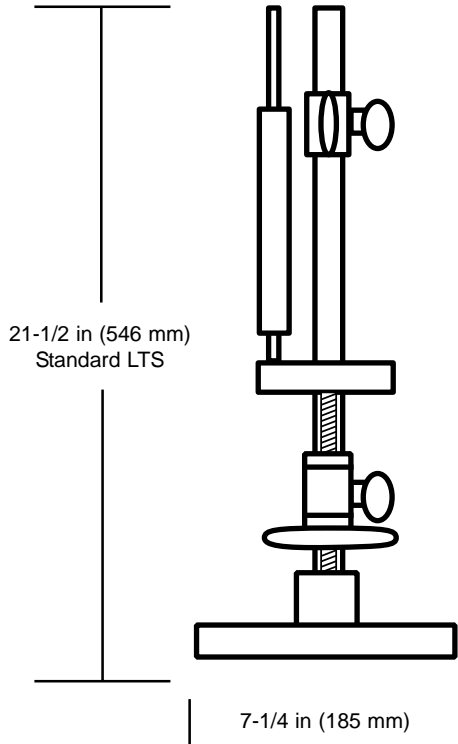

STANDARD ACCESSORIES

	Part No.
Dial Indicator Kit	LTCK-1
Dial Indicator Kit (Metric)	LTCK-1METRIC
Gauge Adapter Kit for DFGS-R	NC000300

GAUGE SELECTION

DPP Series (All capacities)
DFM Series (All capacities)
DFIS Series (DFIS2 thru DFIS100)
DFGS Series (DGGs thru DFGS100)
DFGS-R Series (DGGs-R-250 thru DFGS-R-100) (Requires Adapter)
DFT Series (DFT2 thru DFT100)
DFA Series (DFA250G thru DFA100)
DFA-R Series (DFA-R-250G thru DFA-R-100)

AMETEK

TEST AND CALIBRATION INSTRUMENTS

Americas

AMETEK TCI Division
8600 Somerset Drive
Largo, Florida 33773
Tel +1-727-536-7831
Tel +1-800-527-9999
Fax +1-727-539-6882
Email force@ametek.com

Europe

Lloyd Instruments/AMETEK
12 Barnes Wallis Road
Segensworth East, Fareham
Hampshire, United Kingdom
PO15 5TT
Tel +44-1489-576211
Fax +44-1489-578594
Email
lloyd-instruments@ametek.co.uk

Asia Pacific

AMETEK Singapore Pvt. Ltd.
10 Ang Mo Kio Street 65
#05-12 TECHPOINT
Singapore 569059
Tel +65-484-2388
Fax +65-481-6588
E-Mail aspl@ametek.com.sg

Distributed By

**ISO 9001
Manufacturer**